

**Black Pearl**  
Item No. MMS012



It is highly recommended that you visit [www.metalearth.com/360/mms012](http://www.metalearth.com/360/mms012) to see the completed model before assembling your own

**Legends:**

- Engraved side
- Non-engraved side
- Attention point
- Insert tab and bend 90 degrees
- Insert tab and twist 90 degrees

**Recommended tools:**

- Wire cutters: helpful for taking parts from the metal sheets.
- Tweezers or needle nose pliers: helpful for folding parts, bending and twisting tabs.

**Assembly tip:**  
If needed, slightly twist tabs to hold parts together then untwist and bend them down for a nice finish

Insertion tabs are inserted and then folded  
Fold lines can be seen as shown here  
Insertion holes

### Metal sheets

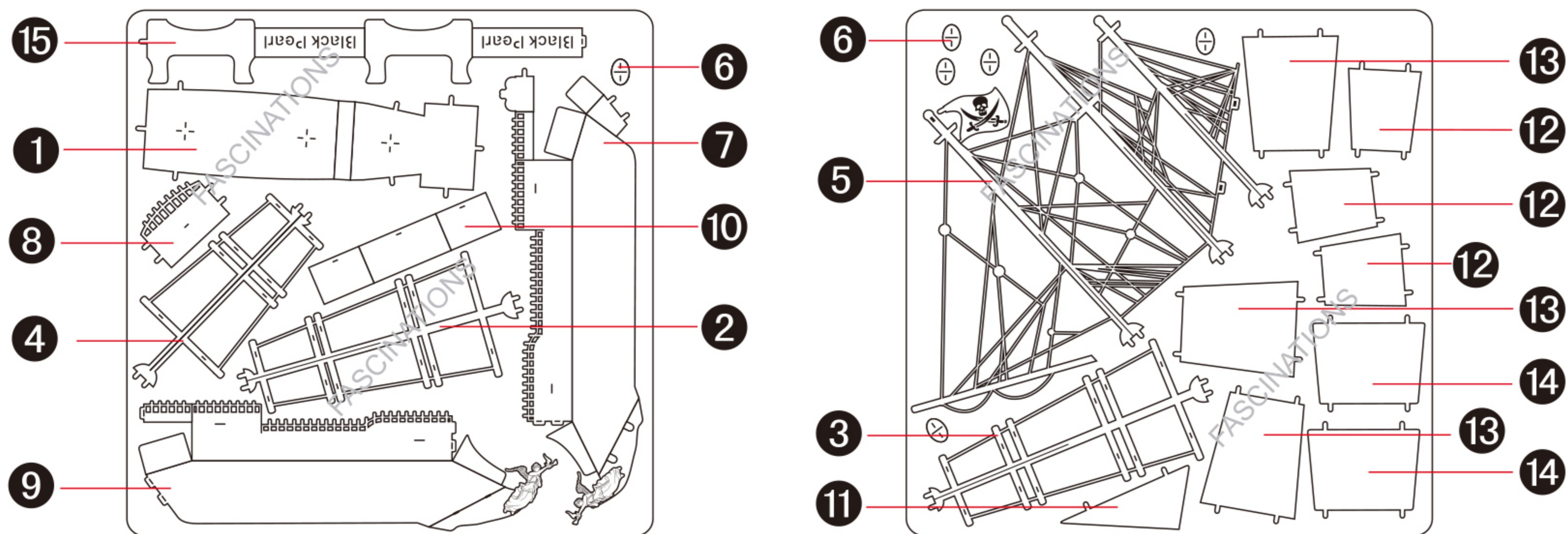

In order to avoid possible injury from sharp edges, please carefully discard the metal sheet after parts have been removed

### Assembly Flow Chart

