

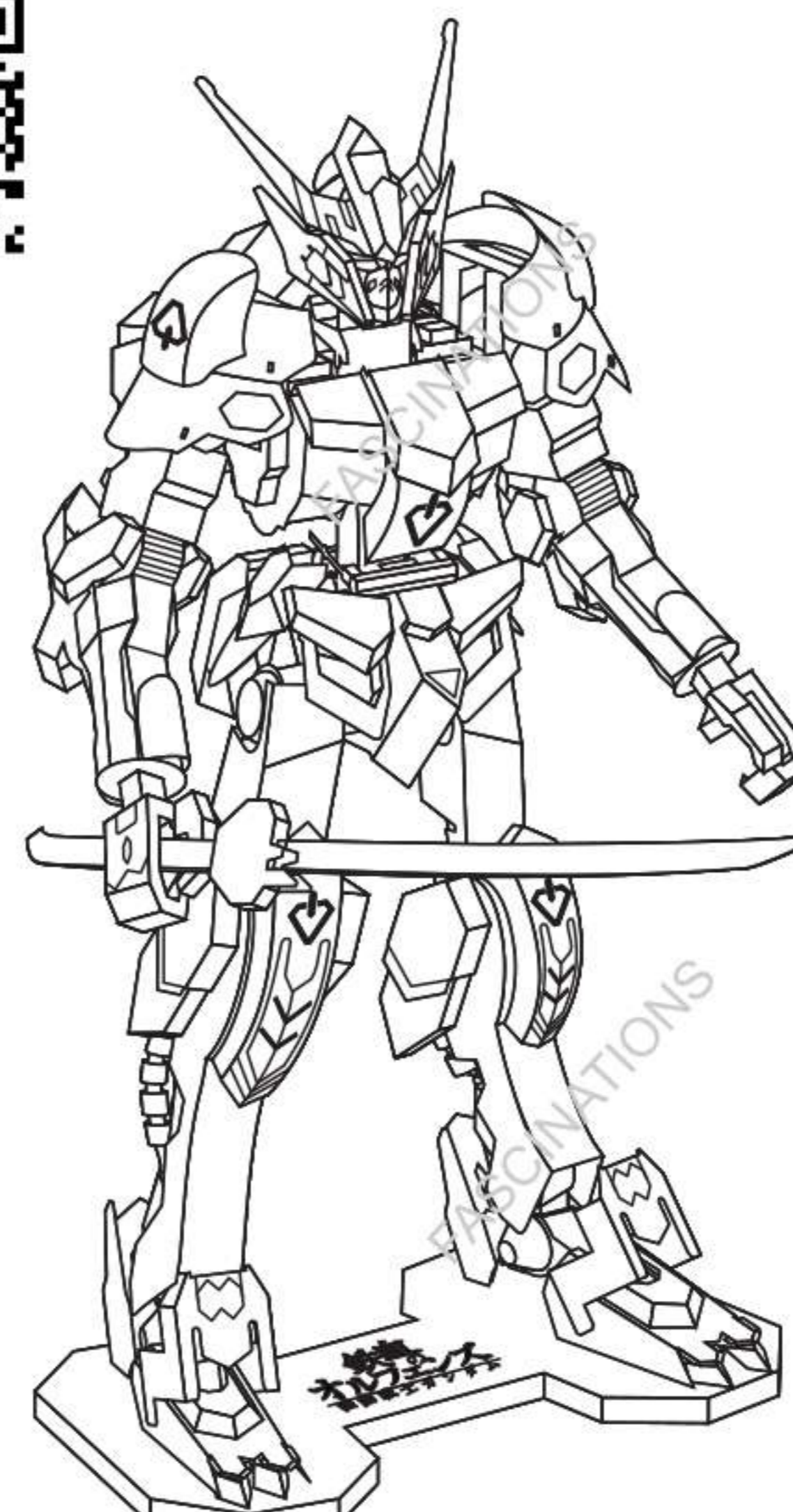

It is highly recommended that you visit [www.metalearth.com/360/icx105](http://www.metalearth.com/360/icx105) to see the completed model before assembling your own

Go to [www.metalearth.com/360/icx105](http://www.metalearth.com/360/icx105) to see the zoomable PDF version of this instruction sheet

## ICX105 GUNDAM BARBATOS



©SOTSU • SUNRISE • MBS PLEX 2017 MADE IN CHINA

## TO CREATE THE BEST CONNECTIONS

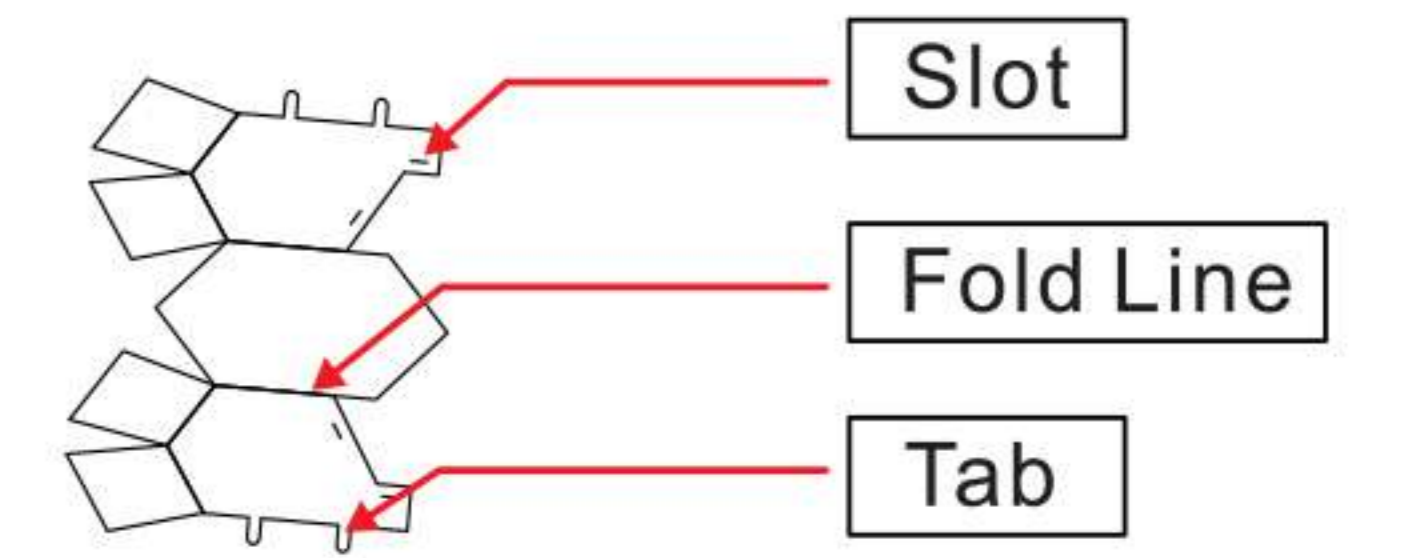

### Legends:

- Engraved side
- Non-engraved side
- Attention point
- Insert tab and bend 90 degrees
- Insert tab and twist 90 degrees

### Recommended tools:

- Wire cutters: helpful for taking parts from the metal sheets.

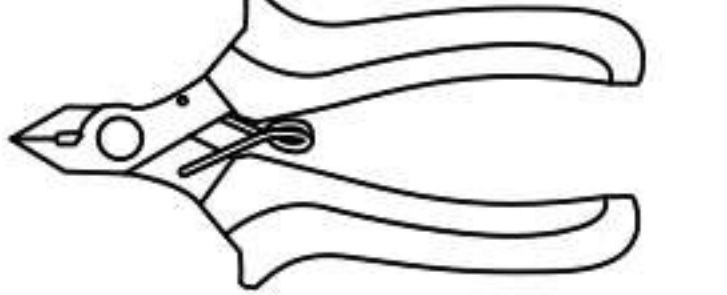

- Tweezers or needle nose pliers: helpful for folding parts, bending and twisting tabs.

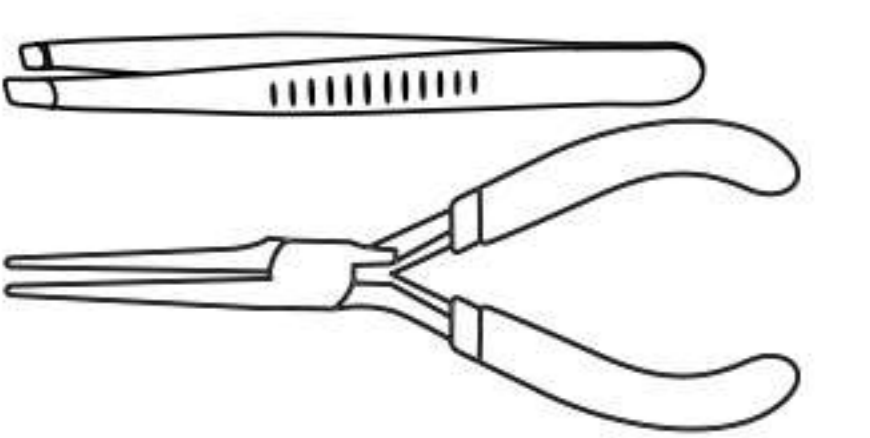

### Assembly tip:

If needed, slightly twist tabs to hold parts together then untwist and bend them down for a nice finish.

## METAL SHEETS

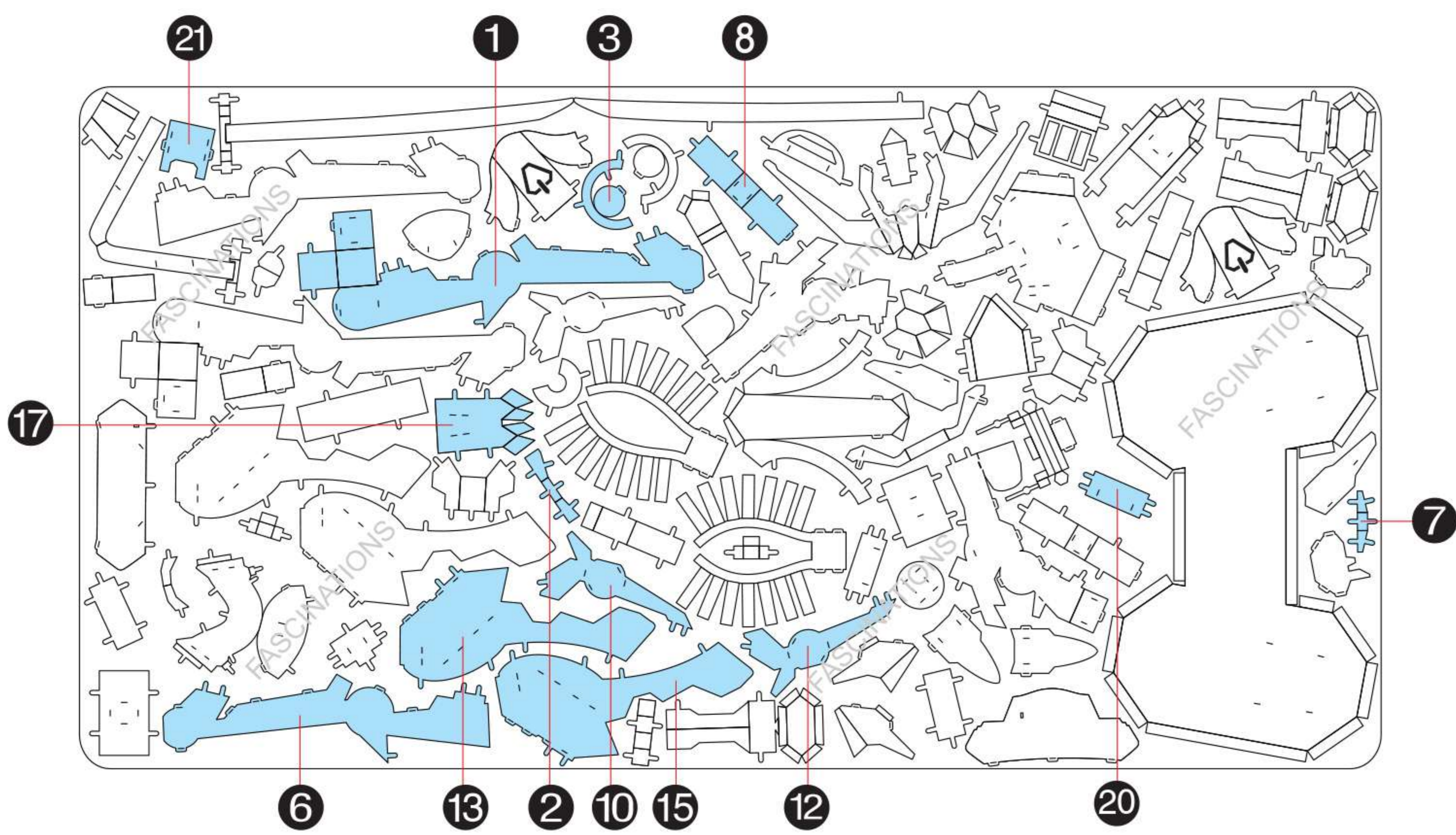
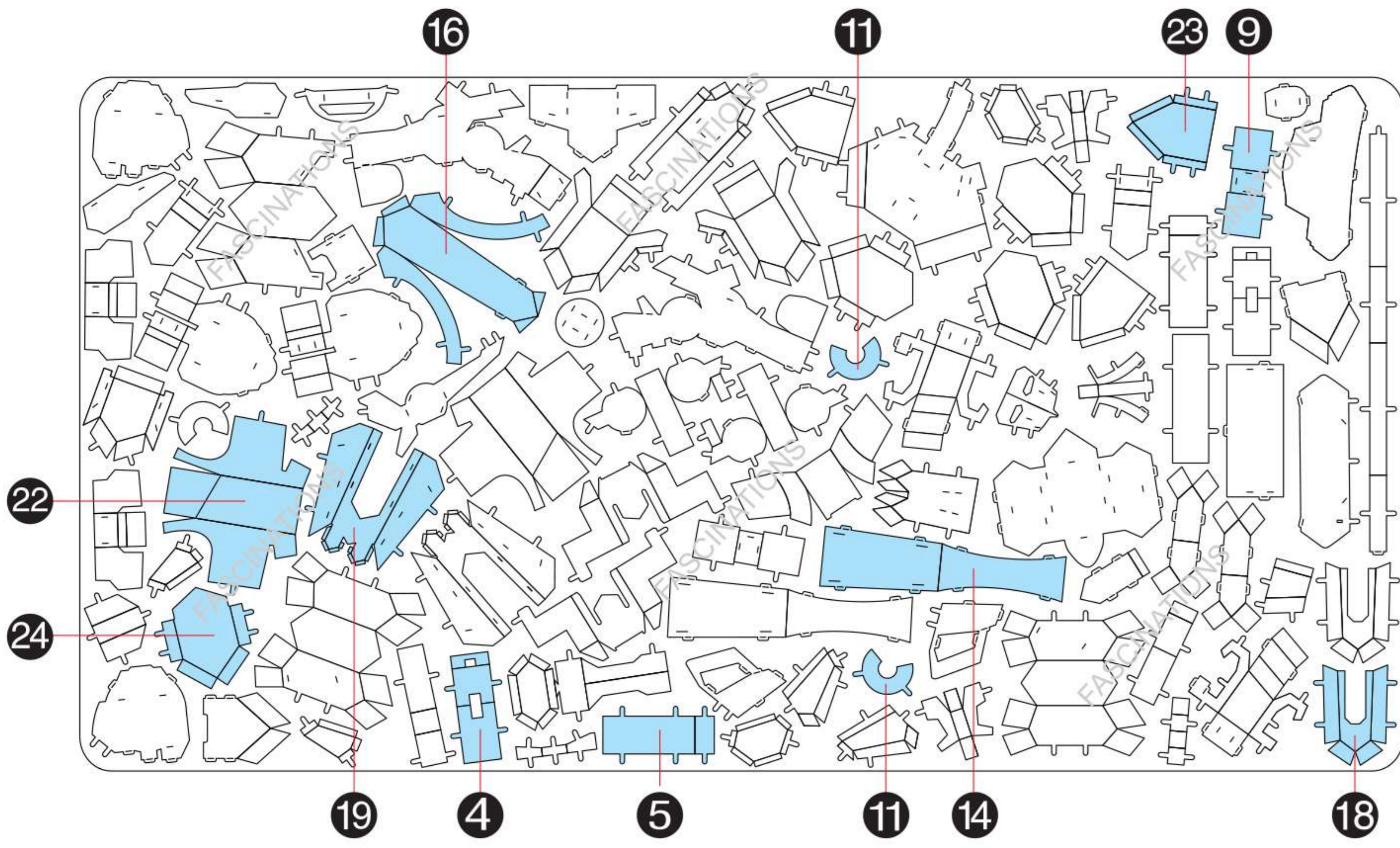

In order to avoid possible injury from sharp edges, please carefully discard the metal sheet after parts have been removed.

## ASSEMBLY STEPS

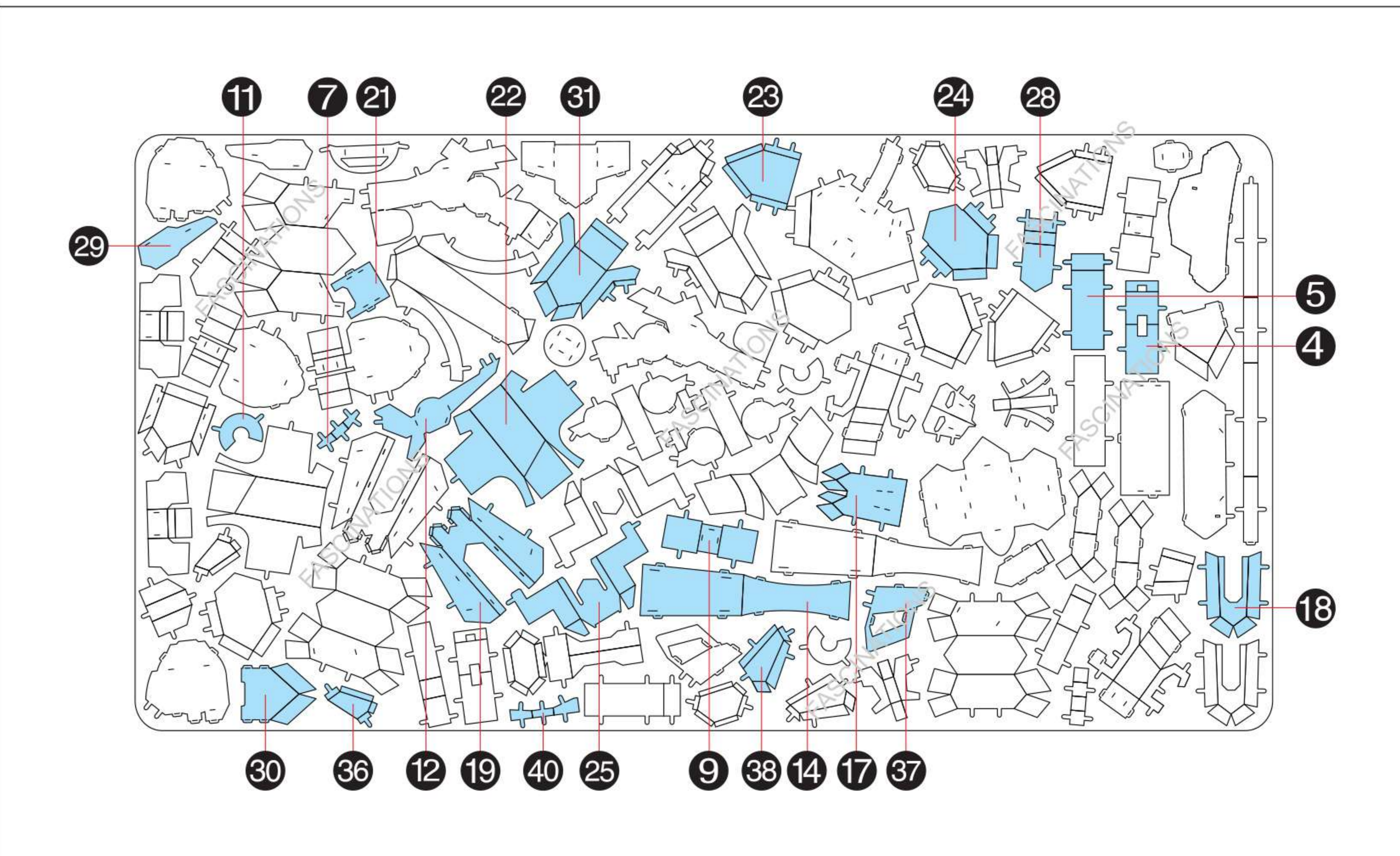
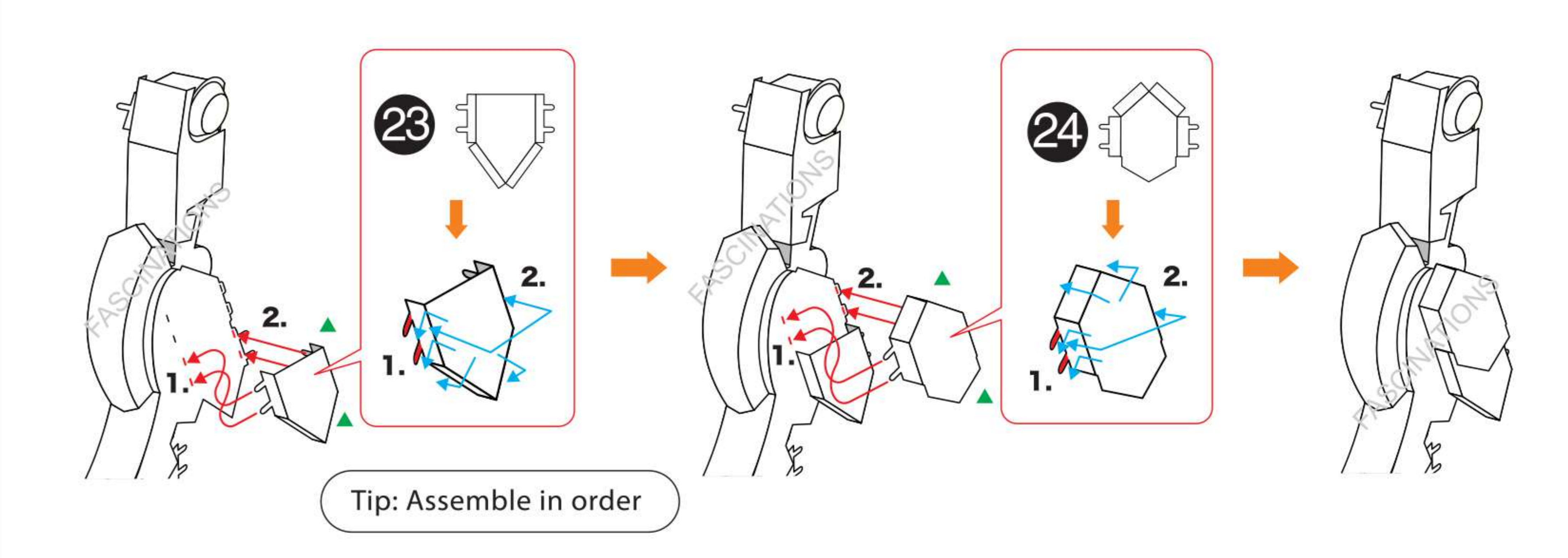
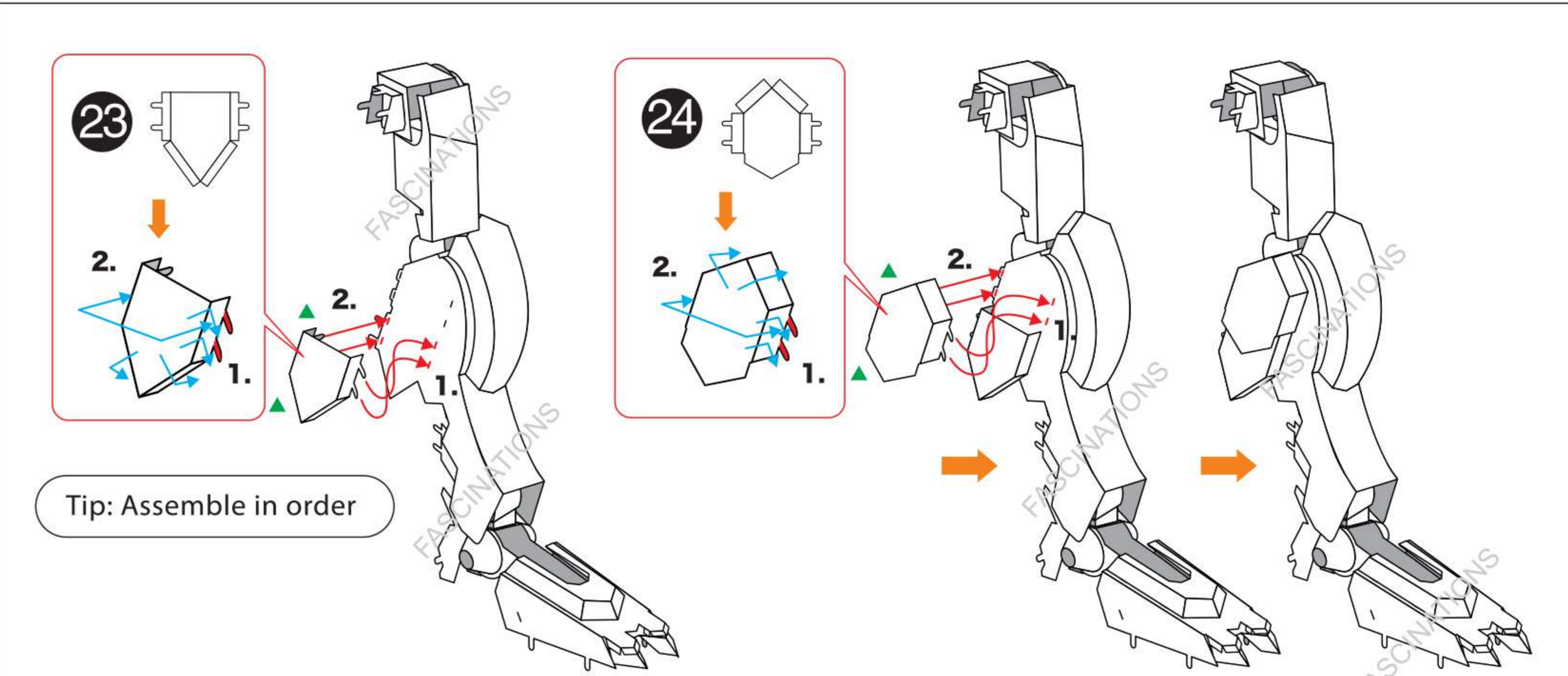
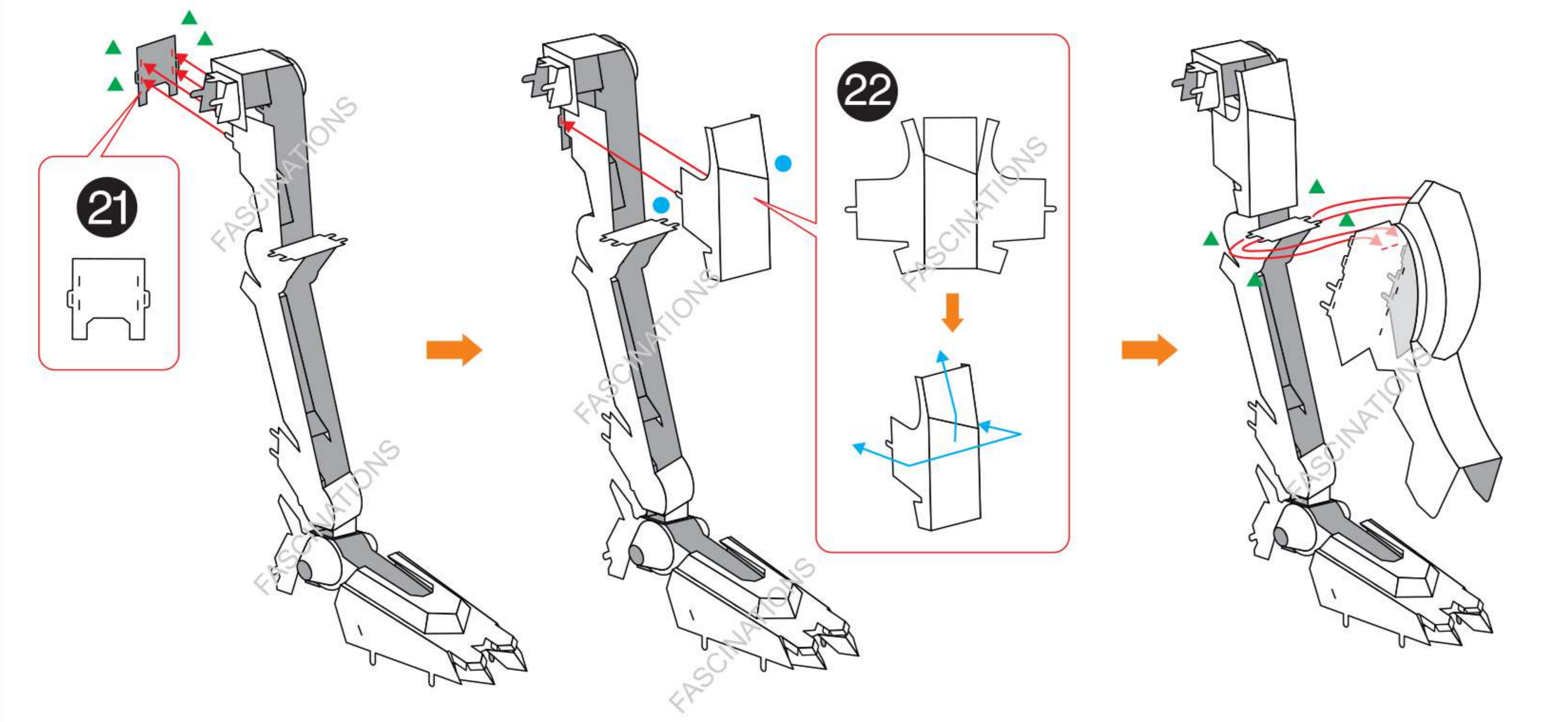
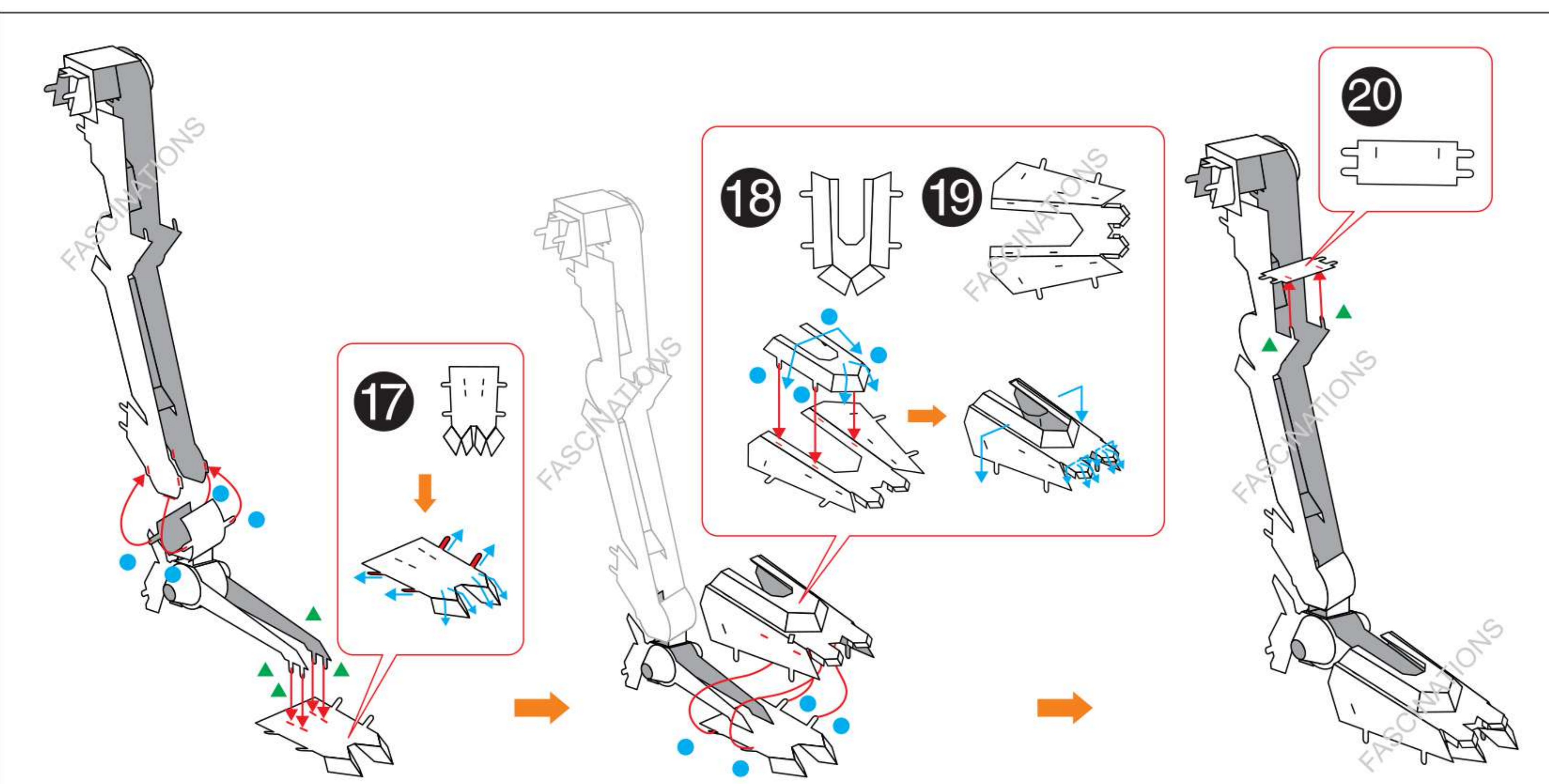
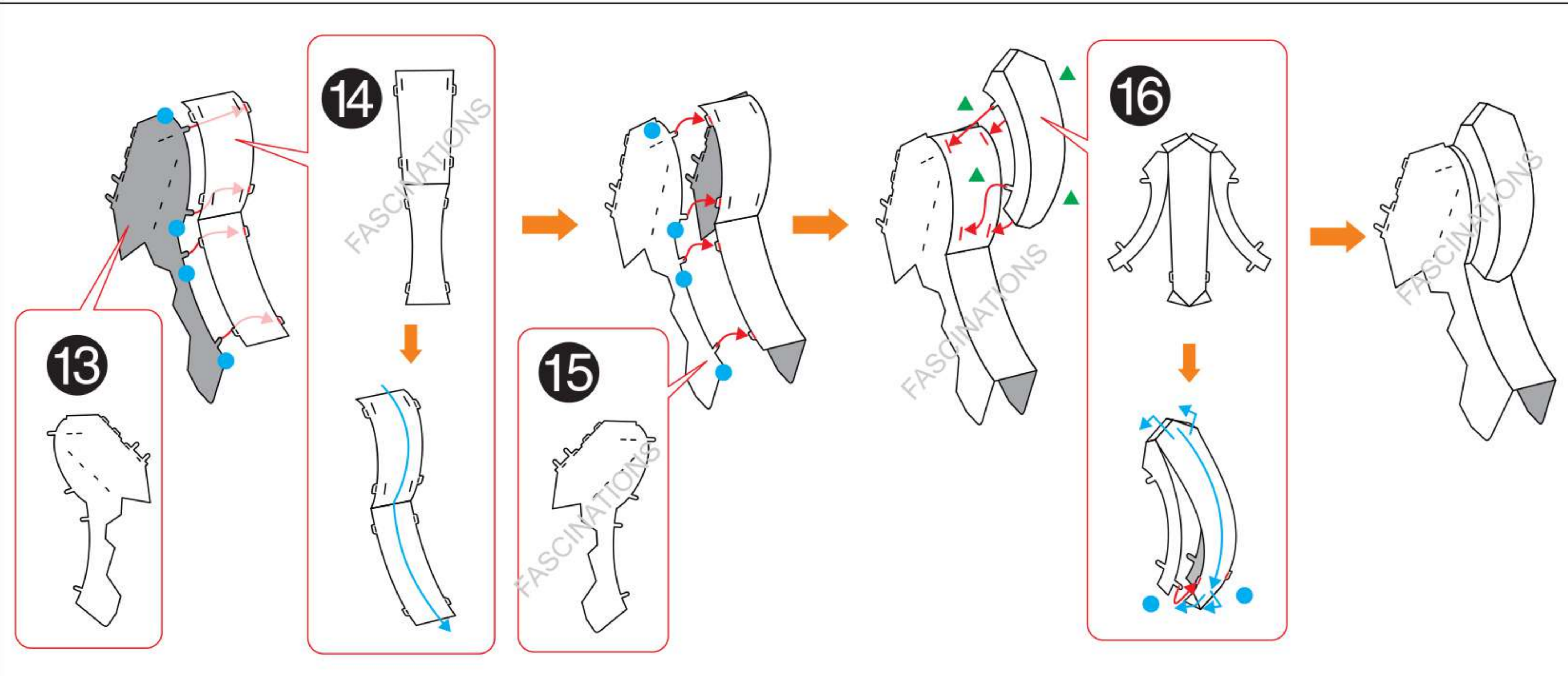
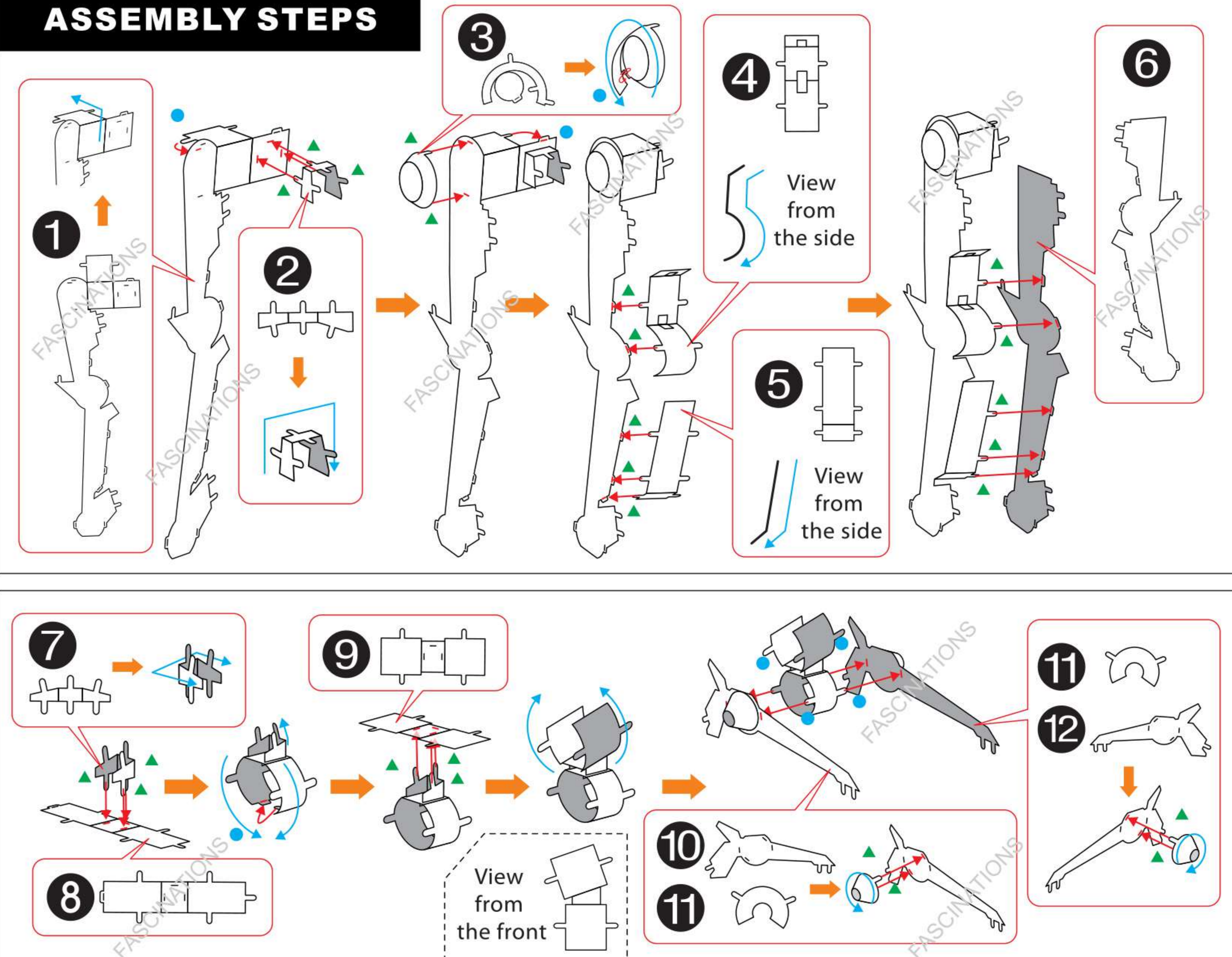

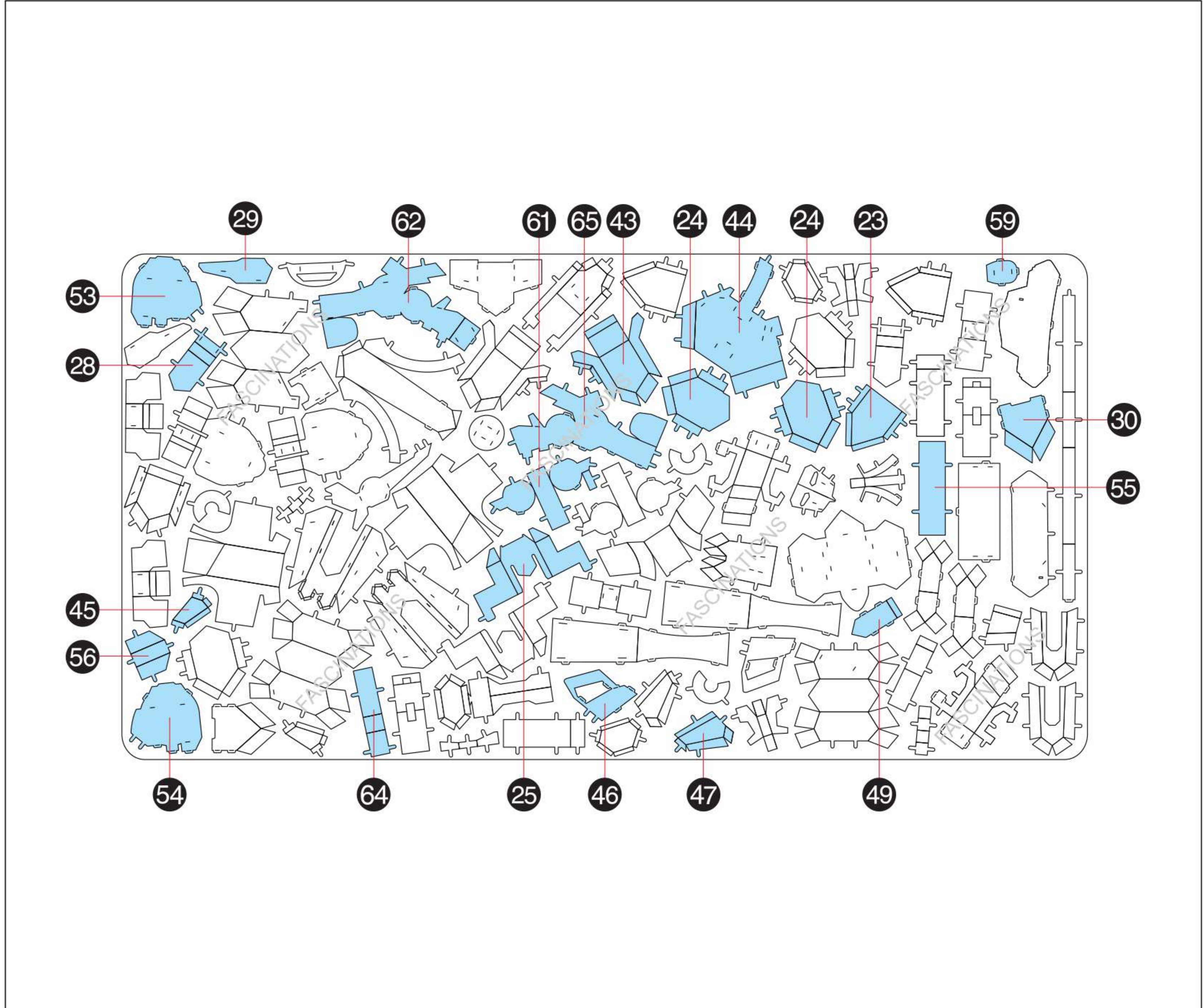
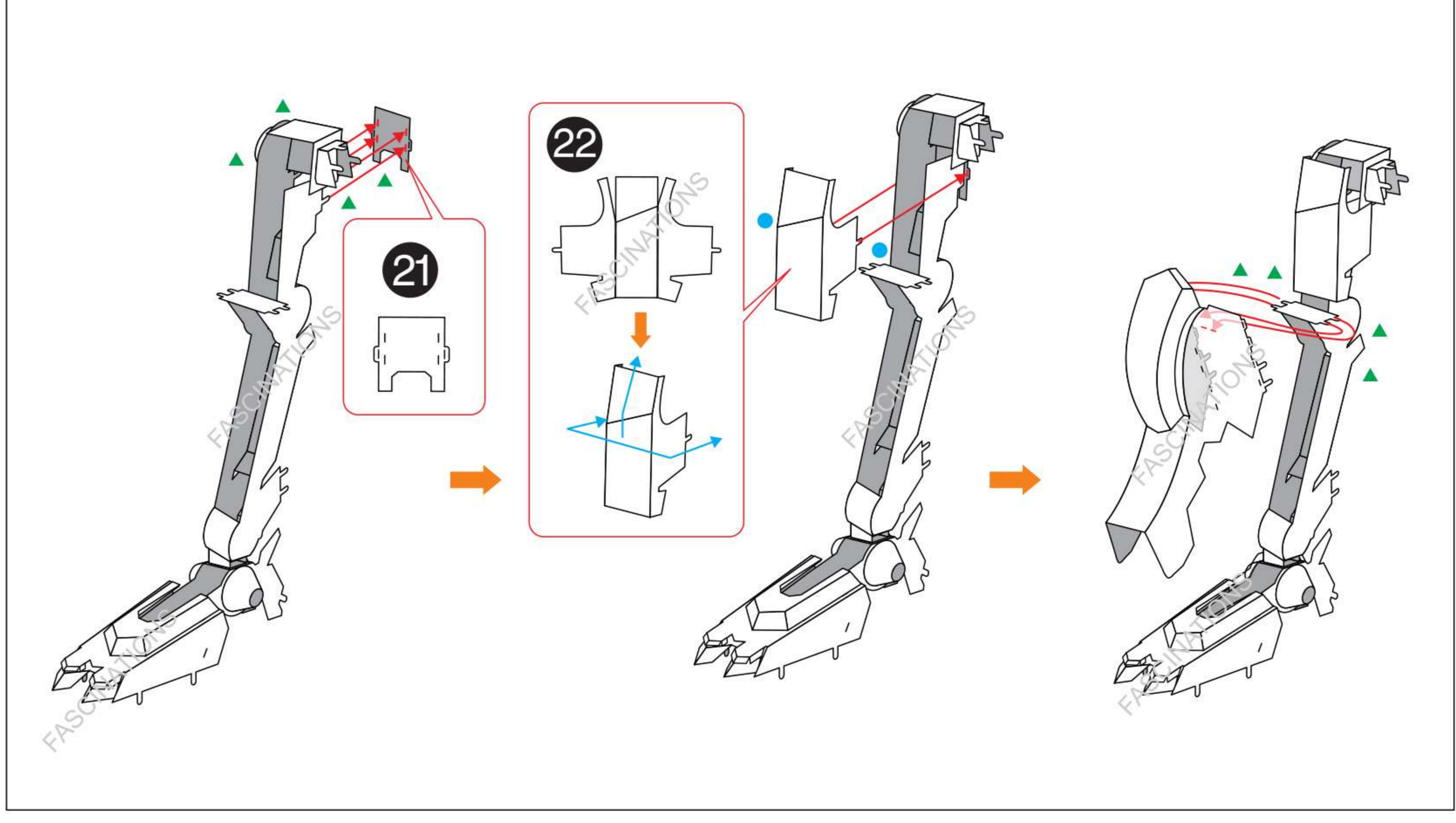
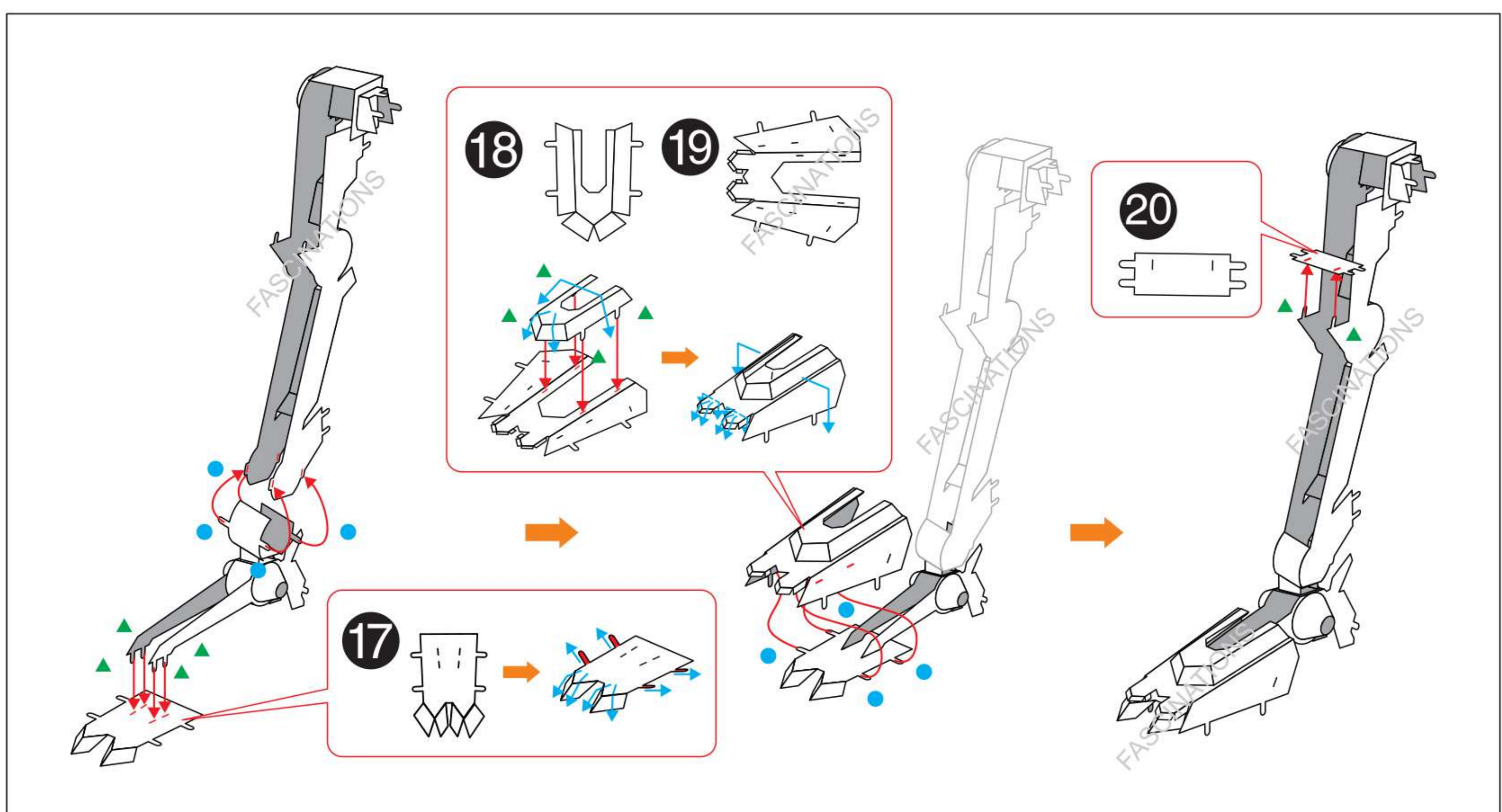
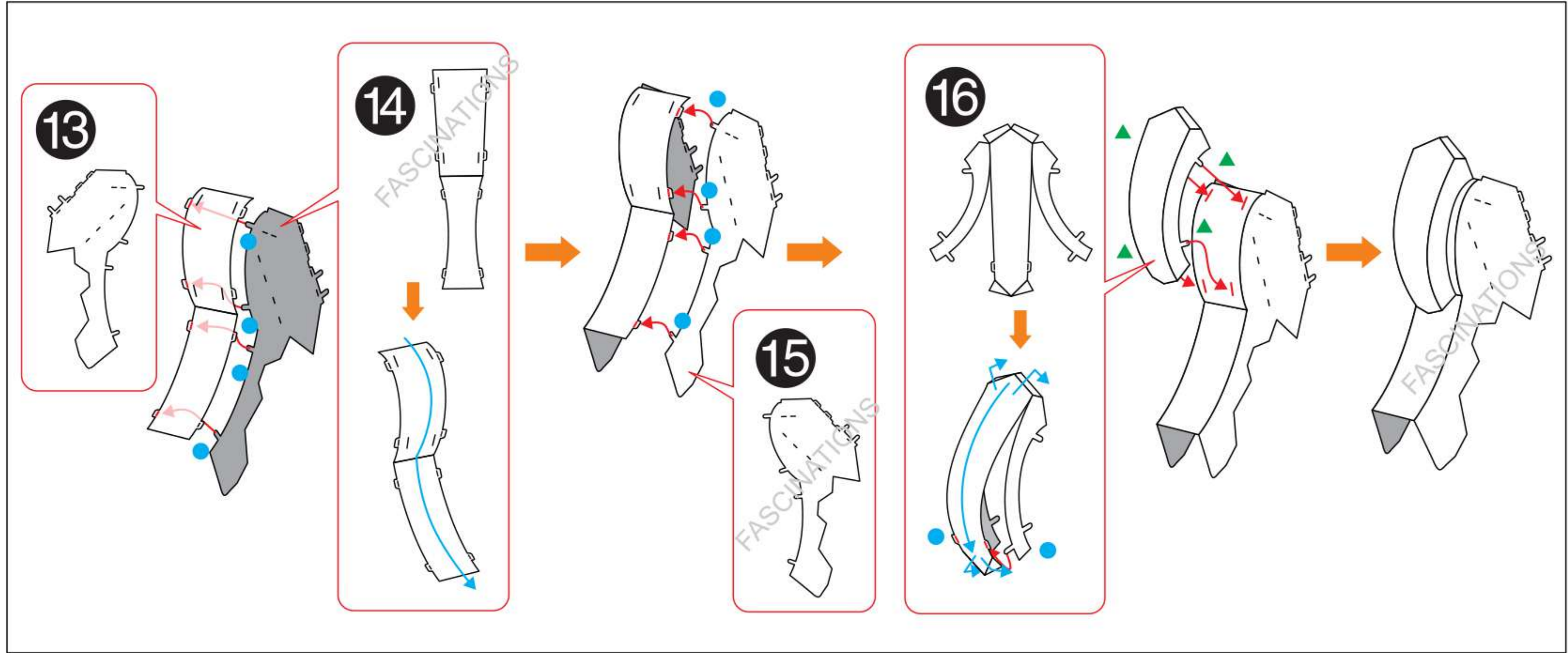
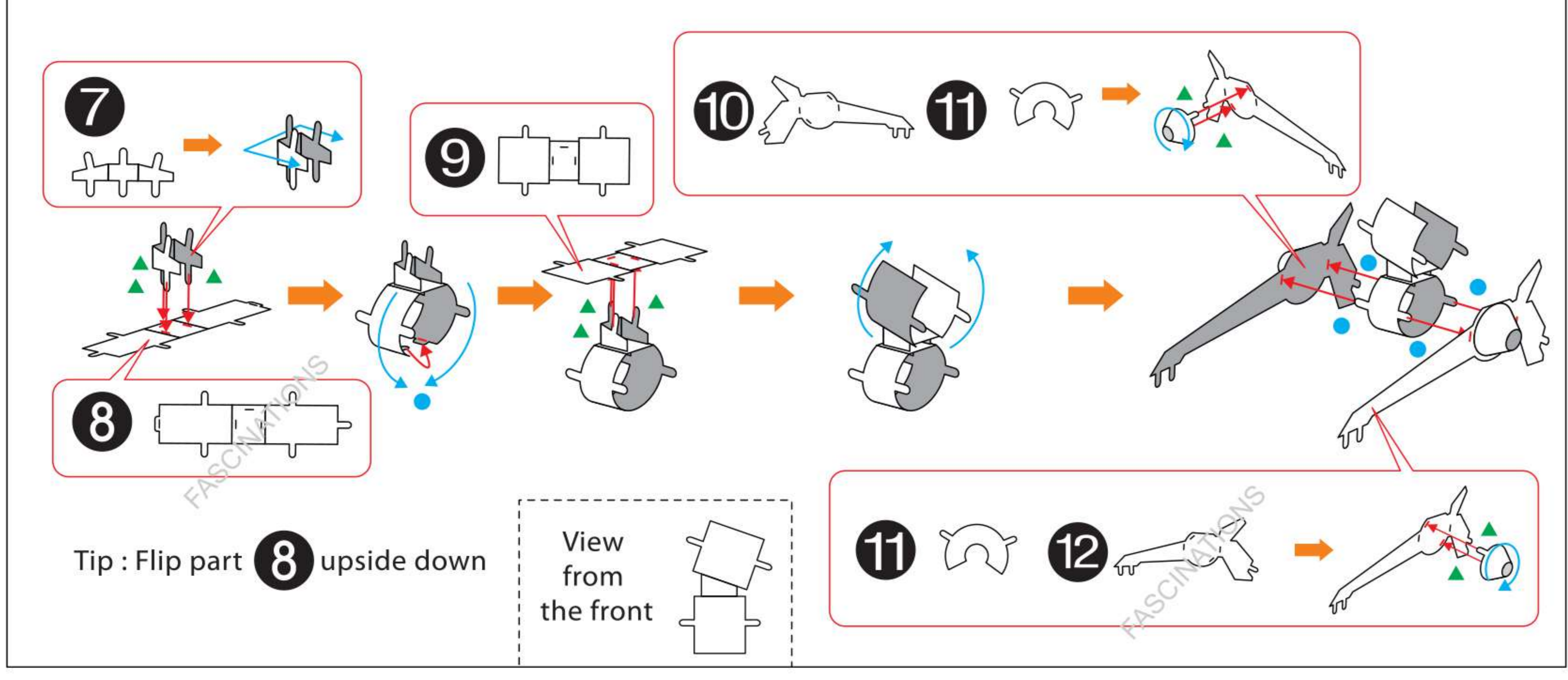
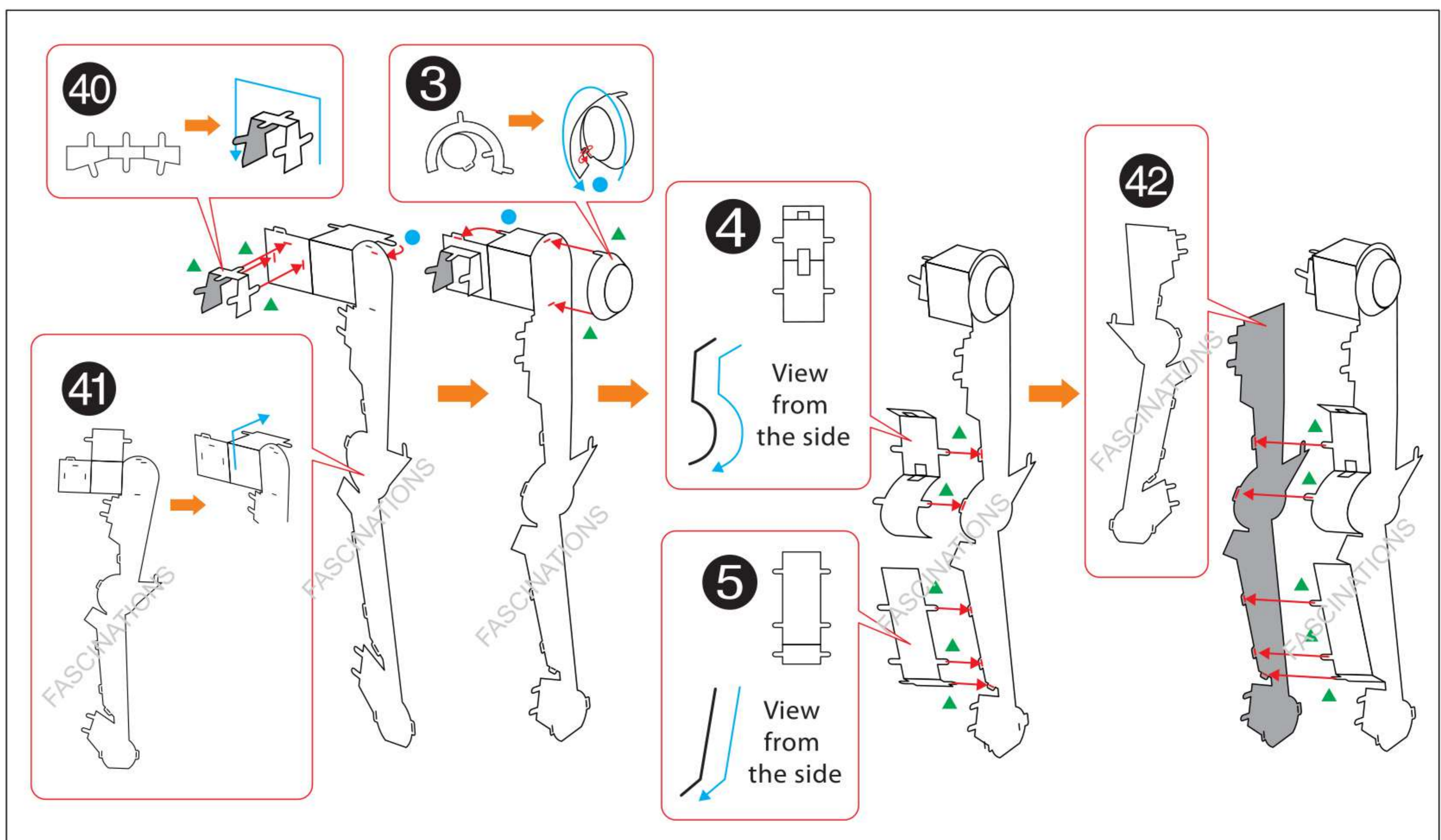
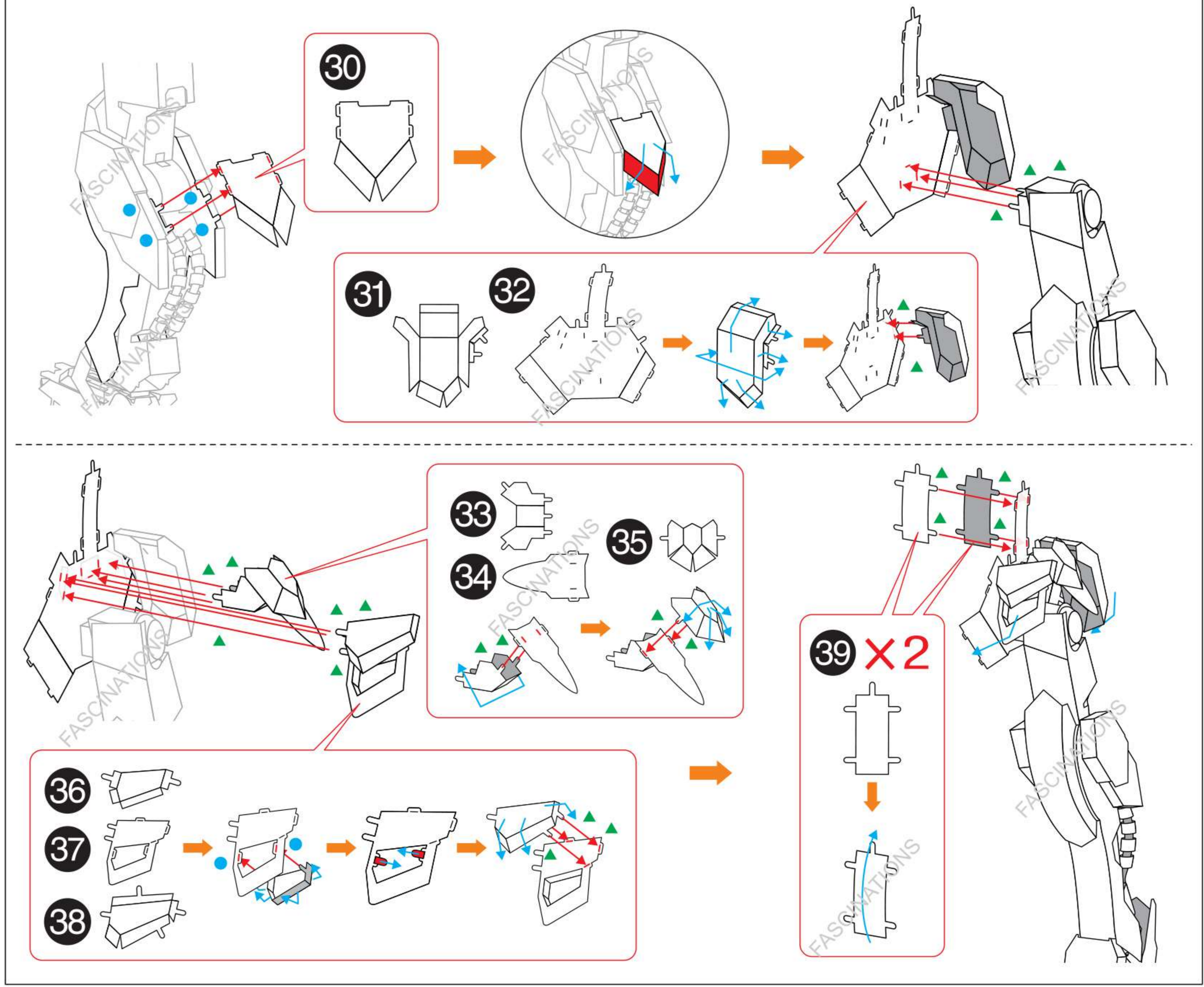
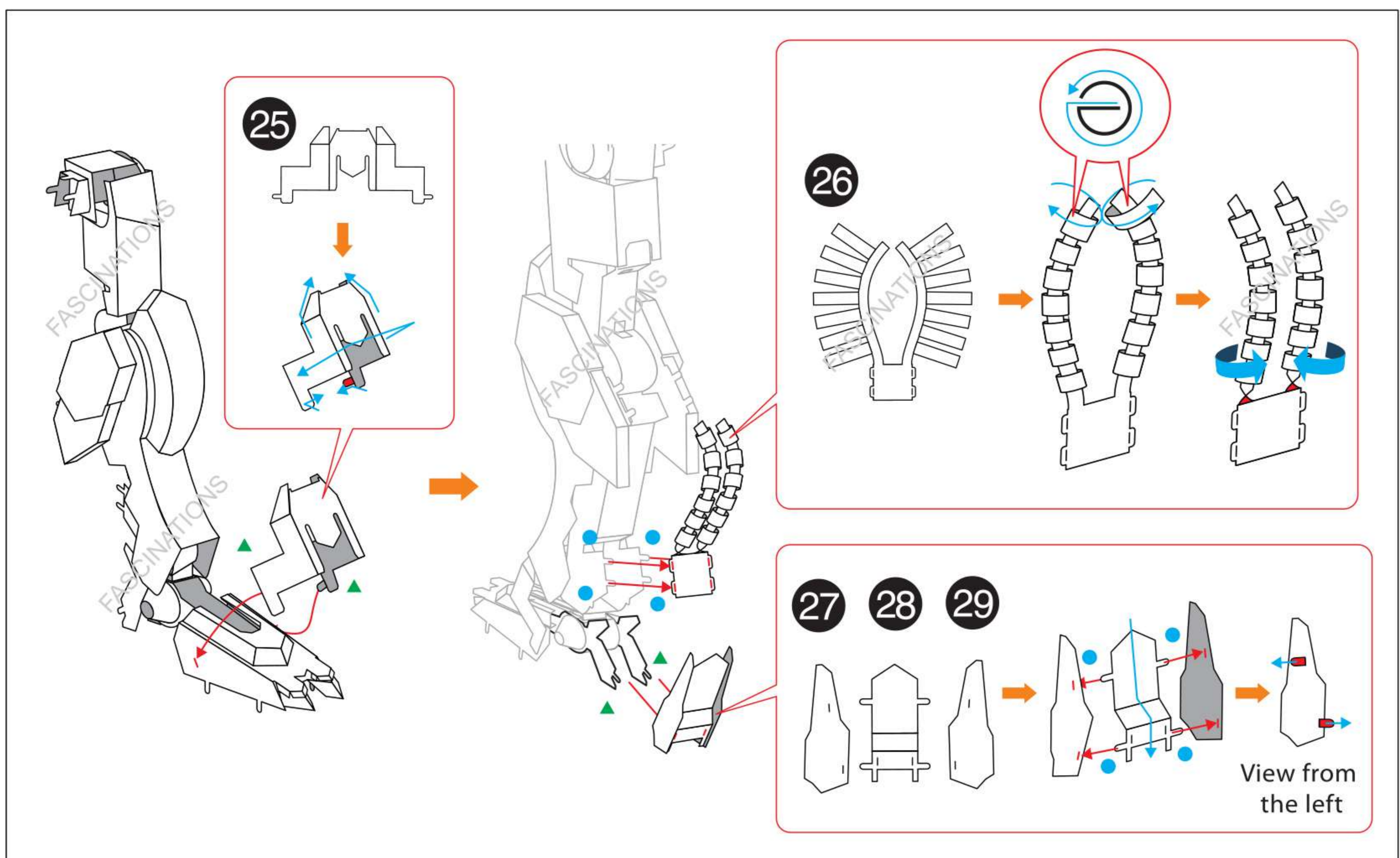
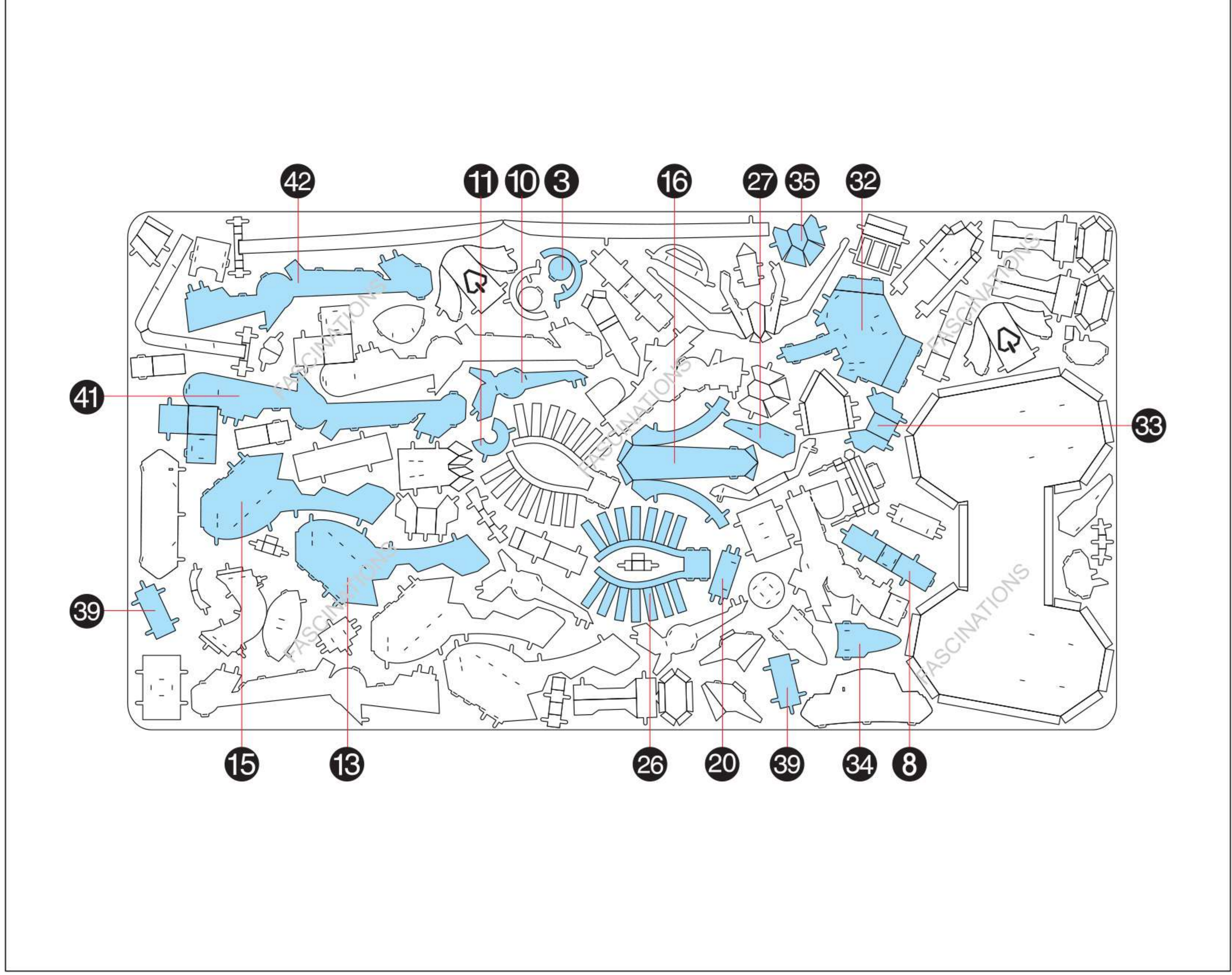

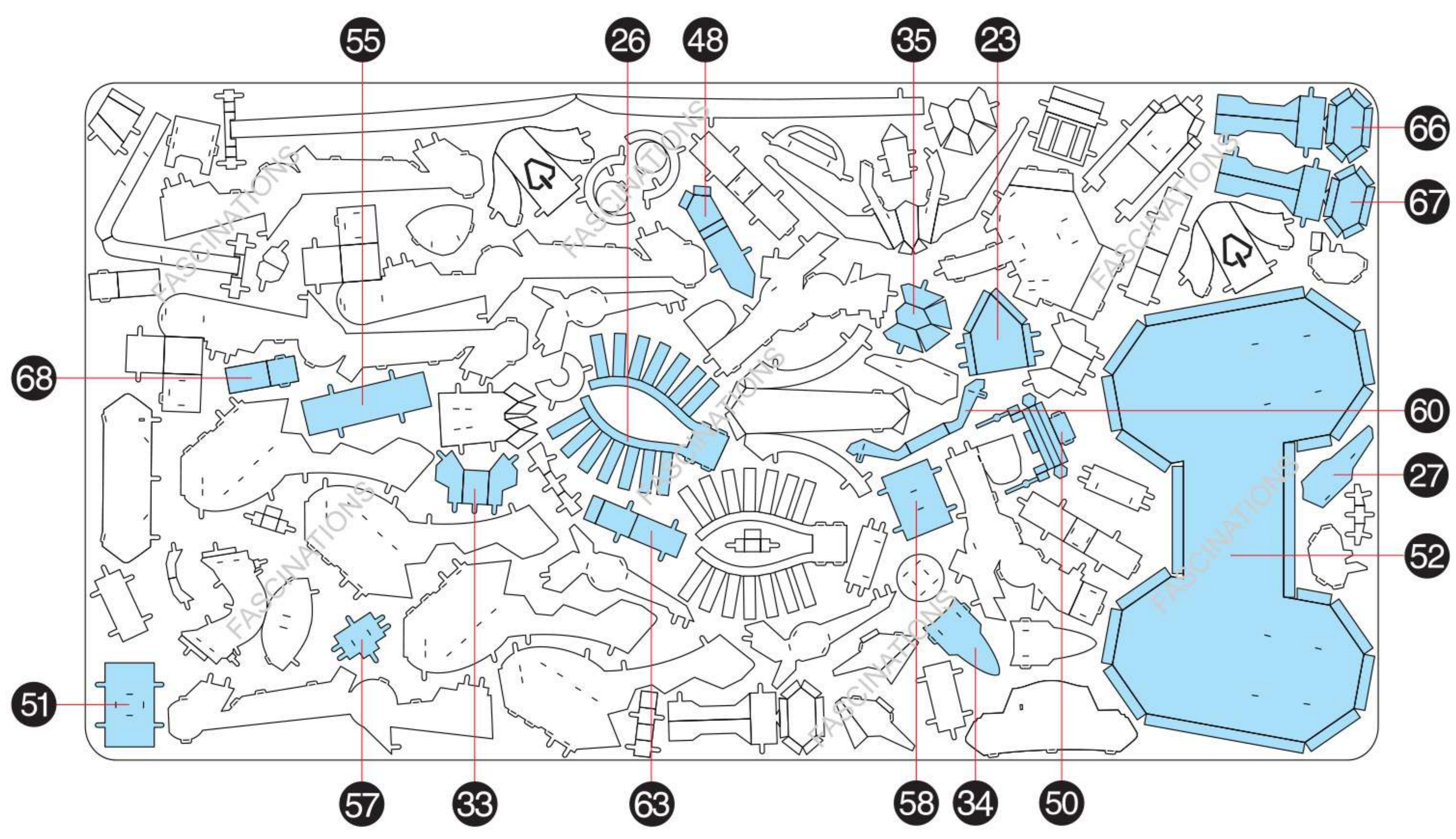

Tip : pay attention to the red tabs

